

# Angular Hand Grips, 180°

Bores from 16 to 32 mm

Double acting



Executions		
Version	Code	Item
Bore 16 mm	075013	16PAC
Bore 20 mm	075017	20PAC
Bore 25 mm	075024	25PAC
Bore 32 mm	075062	32PAC



Series of pneumatic 180° angular hand grips available in 4 different sizes.

They are standard magnetic with groves on the body allowing the direct mounting of magnetic reed switches.

For magnetic reed switches type ASC see from page 1.110.1. For mounting accessories see from page 1.80.60.

How to order : 25PAC

25	PAC
Bore	Type

Technical data					
Type	16 PAC		20 PAC	25 PAC	32 PAB
Fluid	Compressed filtered air				
Pressure range	1,5 ÷ 7 bar				
Temperature	0 °C ÷ + 80°C				
Max. operation frequency	180 cycle / min.				
Lubrication	Piston : with or without lubrication				
	Levers : lubrication is required on moving parts				
Holding moments M* (Ncm)	Closing*	8 x P	17 x P	34 x P	61 x P
	Opening*	11 x P	23 x P	43 x P	81 x P
Effective gripping force F(N)	$F = M / L^{**} \times 0,9$				
Maximum length of gripping point L (mm)	80	100	120	140	140
Weight (g)	140	240	400	700	700
Lever open/close angle	- 1° ÷ + 186°				
Ports	M5				

\* P = operating pressure (bar)

\*\* L = distance of the gripping point (mm)

# Angular Hand Grips, 180°

Bores from 16 to 32 mm

Double acting



## Materials

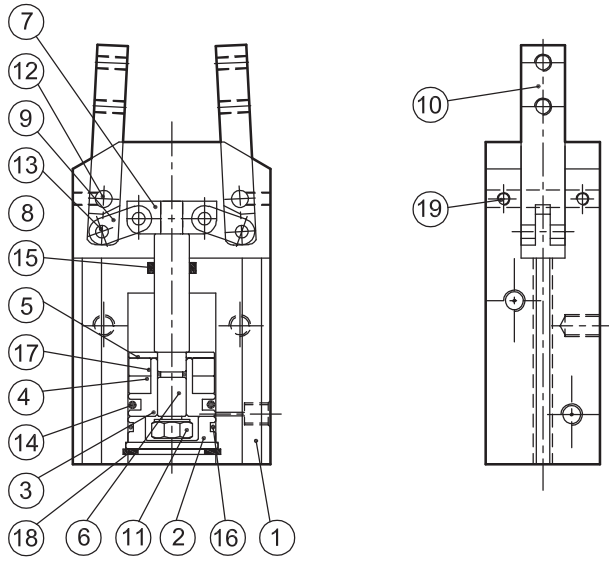

N.	Component	Material
1	Body	Aluminium
2	End cover	Aluminium
3	Piston	Brass
4	Magnet	Plastic magnet
5	Magnet holder	Brass
6	Piston rod	Stainless steel
7	End piston rod joiner	Steel alloy
8	Piston rod pin	Steel
9	Action lever	Steel alloy
10	Fingers	Steel alloy
11	Nut	Steel
12	Slide pin	Steel
13	Action lever pin	Steel
14	Piston seal	NBR
15	Piston rod seal	NBR
16	End cover O-ring	NBR
17	Piston rod O-ring	NBR
18	Seeger	Steel
19	Hexagonal screw	Steel alloy

## Gripping forces

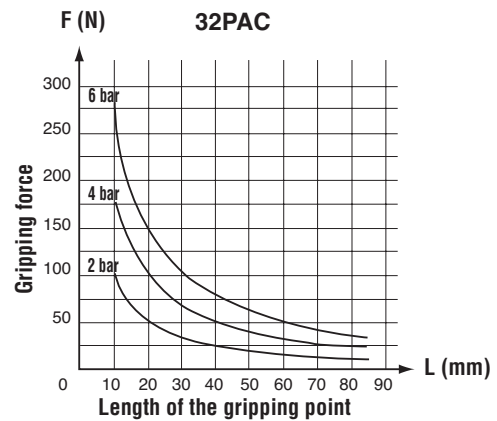
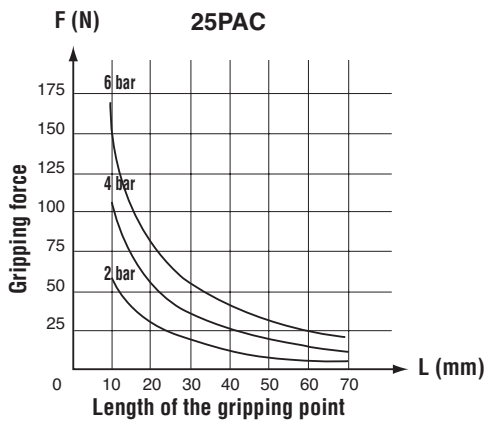
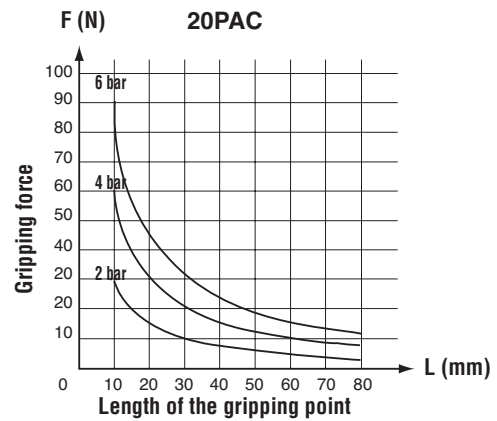
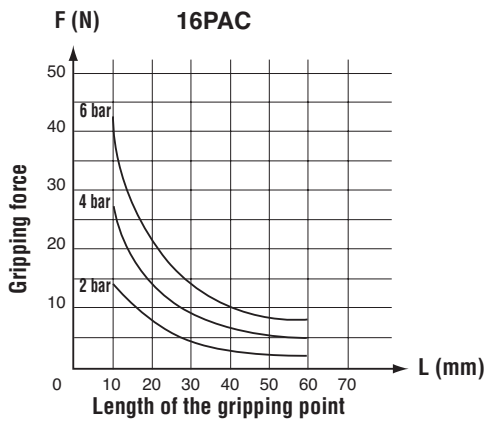

# Angular Hand Grips, 180°

Bores from 16 to 32 mm

Double acting



type: 16PAC

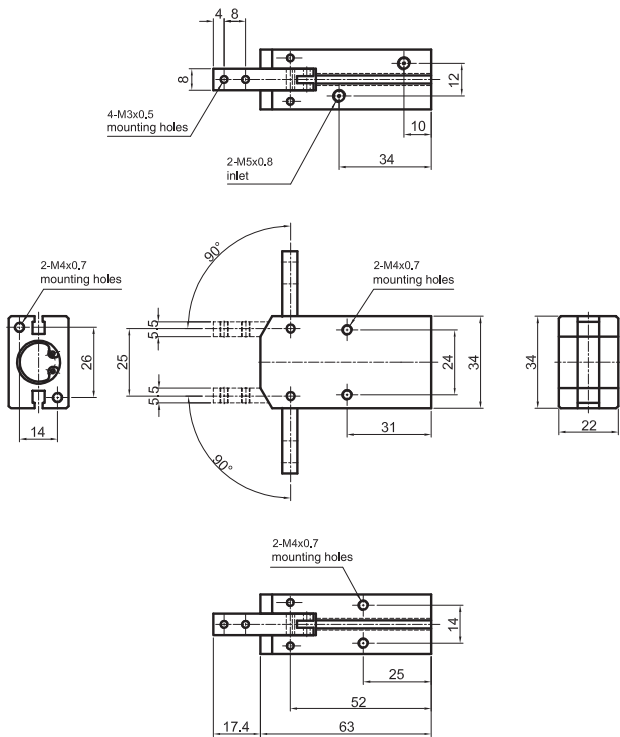

type: 20PAC

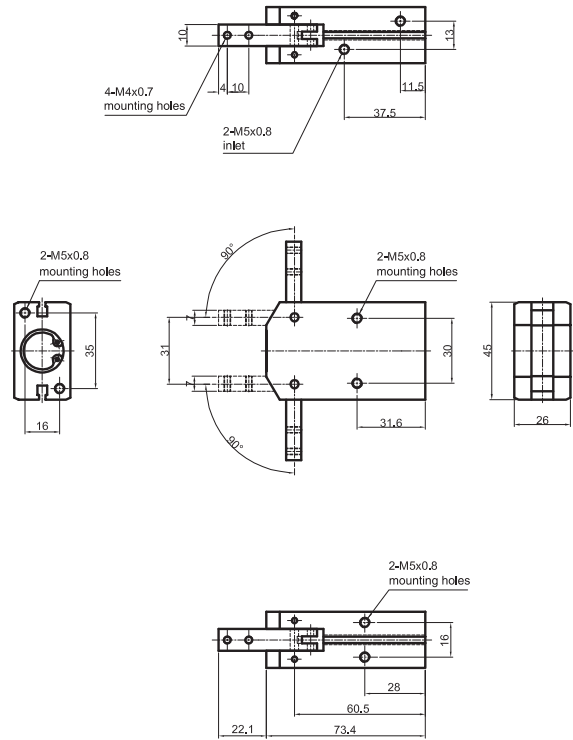

type: 25PAC

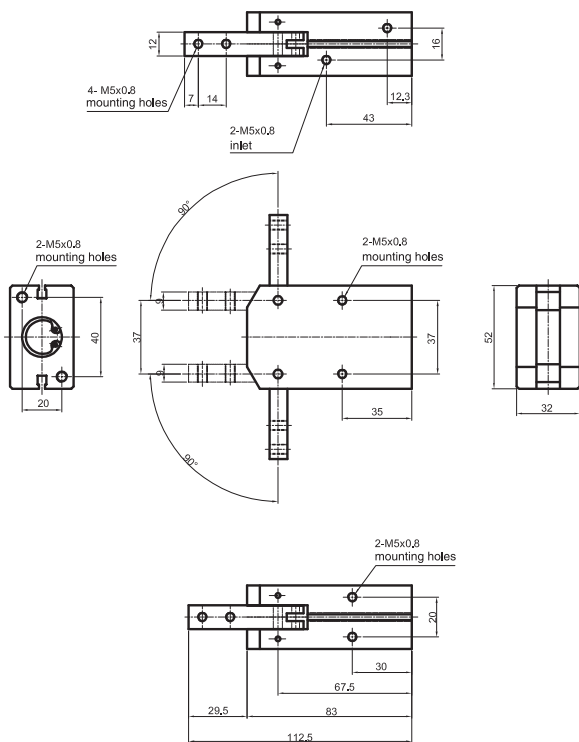

type: 32PAC

