

Slide Units for Cylinders ISO 6432

Bores from 12 to 25 mm

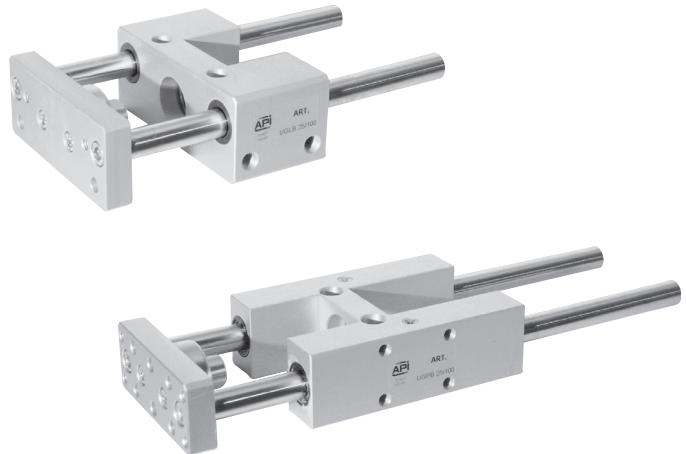

Standard executions		
Version	Symbol	Type
U-shaped (light) with sintered bronze bushings		UGLB
H-shaped (heavy) with sintered bronze bushings		UGPB
H-shaped (heavy) with spherical bearings		UGPS



On request, they can be supplied according Directive 94/9/EC - ATEX
CE **II 2 GDc T5**

Option	Suffix
Rods in stainless steel AISI 304	K
Special versions on request	/ S

The options can be combined (when this is possible)

Series of linear slide units for cylinders ISO 6432 with four possible fixing surfaces. They must be used with heavy loads to guarantee a better linearity of movement and a higher precision. They can sometimes be used as anti-rotating devices too. The versions with spherical bearings slide better but can support lighter loads than the versions with bronze bushings. The U-shaped versions, can support lighter loads than the H-shaped ones.

For loads see pages 1.70.5 - 1.70.10.

How to order: UGPB20/100K

UGPB	20	/	100	K
Type	Cylinder bore	/	Cylinder stroke	Option

Technical data	
Temperature range:	-20 °C ÷ + 70°C
Materials	Body: Anodised aluminium Plate: Anodised aluminium Seals: Polyurethane - Bronze bushing: Sintered bronze Bushings: UGLB - UGPB: Sintered bronze UGPS: Spherical bearings Rods: UGLB - UGPB: Chrome plated steel C45 UGPS: Hardened and chrome plated steel CF51

Cylinder bore (mm)	Standard strokes of cylinders D.A. (mm)	Maximum stroke of cylinders D.A. (mm)
12	10, 25, 50, 80 100, 125, 160 200, 250, 320, 400, 500	1000
16		
20		
25		

Seal kits not available.

Slide Units for Cylinders ISO 6432

Bores from 12 to 25 mm



Type: **UGLB 12/16**

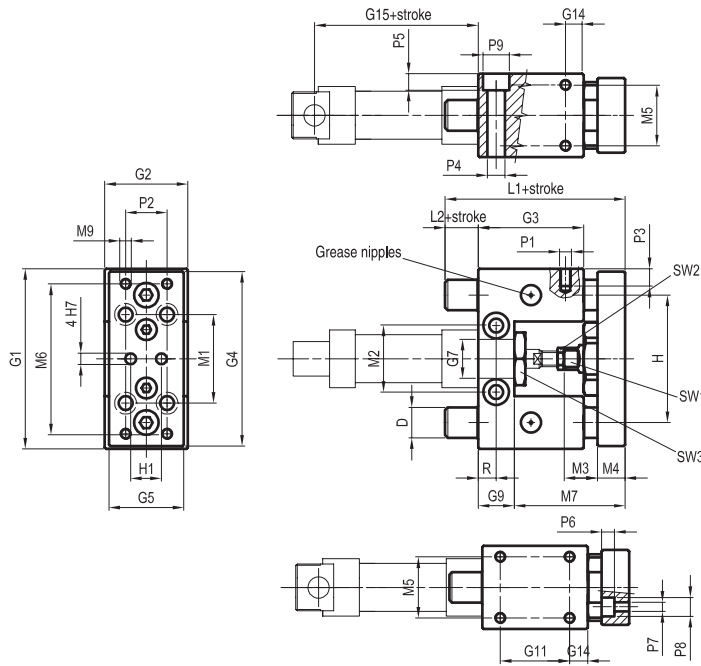

Ø mm	D	G ₁	G ₂	G ₃	G ₄	G ₅	G ₇	G ₉	G ₁₁	G ₁₄	G ₁₅	H	H ₁	L ₁	L ₂	M ₁	M ₂	M ₃
12	10	65	30	38	63	27	16	13	25	6,5	53	46	32	74	10	32	24	12
16	10	65	30	38	63	27	16	13	25	6,5	60	46	32	74	10	32	24	12

Ø mm	M ₄	M ₅	M ₆	M ₇	M ₉	P ₁	P ₂	P ₃	P ₄	P ₅	P ₆	P ₇	P ₈	P ₉	R	SW ₁	SW ₂	SW ₃
12	10	22	54	51	M4	M4	15	8	5,2	5,5	4,5	4,5	7	8,5	6,5	8	10	19
16	12	22	54	51	M4	M4	15	8	5,2	5,5	4,5	4,5	7	8,5	6,5	8	10	19

Type: **UGLB 20/25**

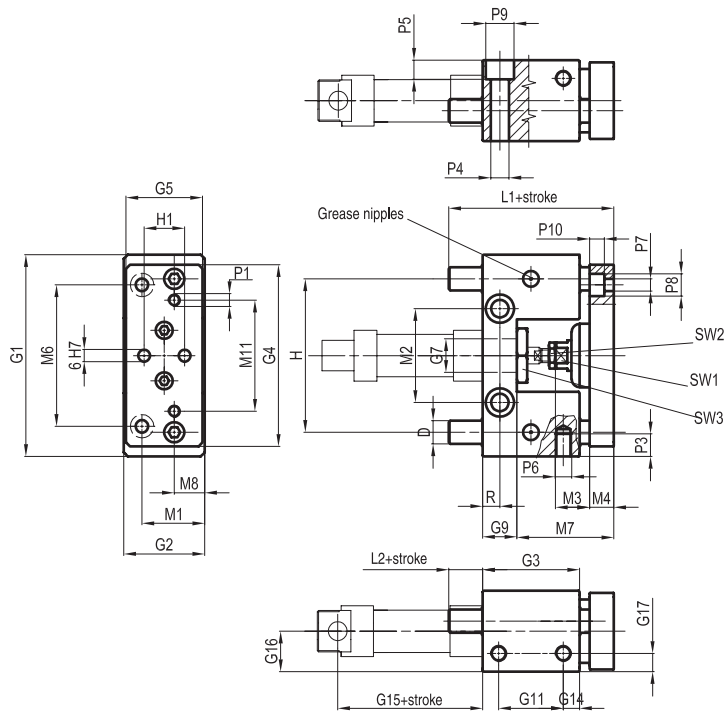

Ø mm	D	G ₁	G ₂	G ₃	G ₄	G ₅	Ø G ₇	G ₉	G ₁₁	G ₁₄	G ₁₅	G ₁₆	G ₁₇	H	H ₁	R	M ₁	M ₂	M ₃
20	12	100	40	48	90	38	22	17	32	8	71	24	10	76	20	8,5	30	46,5	19
25	12	100	40	48	90	38	22	17	32	8	76	24	10	76	20	8,5	30	46,5	19

Ø mm	M ₄	M ₆	M ₇	M ₈	M ₁₁	L ₁	L ₂	Ø P ₁	P ₃	Ø P ₄	P ₅	Ø P ₆	Ø P ₇	Ø P ₈	Ø P ₉	P ₁₀	SW ₁	SW ₂	SW ₃
20	12	70	48	15	55	75	12	M6	15	9	9	M8	6,5	11	14	7	13	13	27
25	12	70	54	15	55	83	12	M6	15	9	9	M8	6,5	11	14	7	13	17	27

Slide Units for Cylinders ISO 6432

Bores from 12 to 25 mm



Type:: UGPB-UGPS

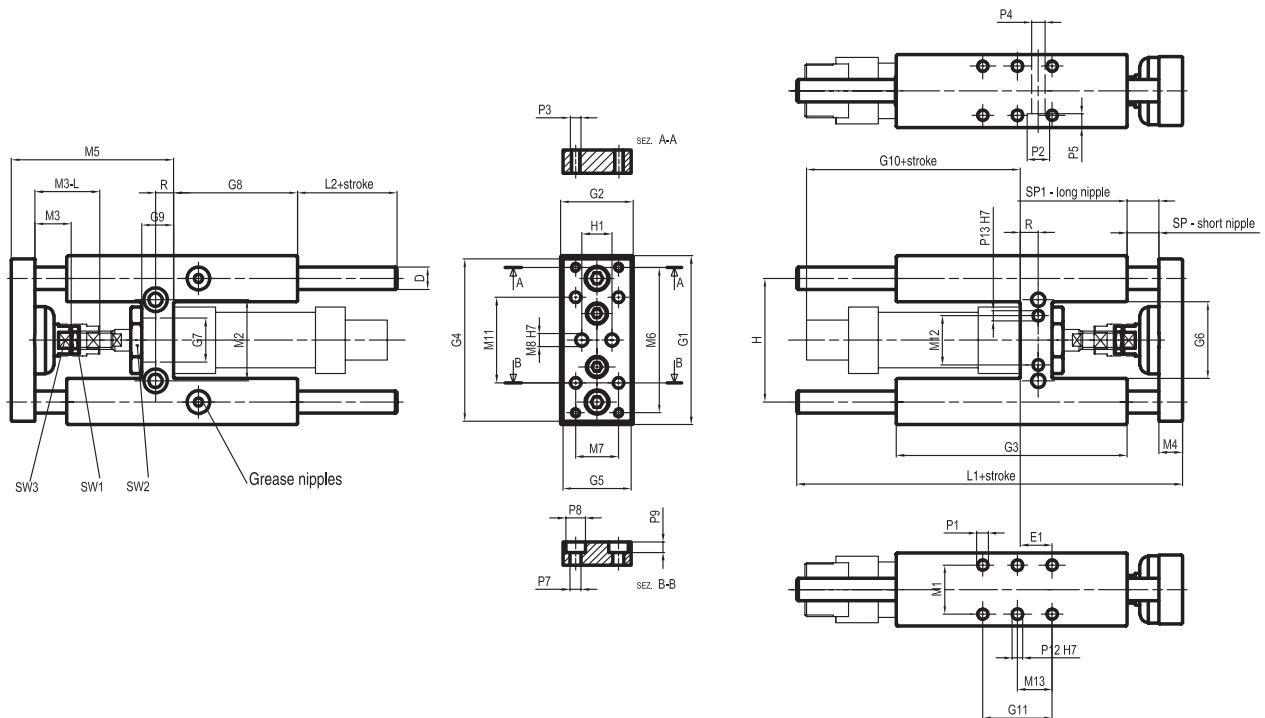

Ø mm	D	E ₁	G ₁	G ₂	G ₃	G ₄	G ₅	G ₆	G ₇	G ₈	G ₉	G ₁₀	G ₁₁	H	H ₁
12	10	11	65	30	75	63	27	27	16	37	13	66	32,5	46	15
16	10	11	65	30	75	63	27	27	16	37	13	71	32,5	46	15
20	12	15	79	34	108	76	32	36	22	58	15	87	32,5	58	20
25	12	15	79	34	108	76	32	36	22	58	15	90	32,5	58	20

Ø mm	L ₁	L ₂	M ₁	M ₂	M ₃	M ₄	M ₅	M ₆	M ₇	M ₈	M ₁₁	M ₁₂	M ₁₃	M _{3L}	P ₁
12	125	37	22	24	12	10	51	54	15	4	32	/	16,25	/	M4
16	125	37	22	24	12	10	51	54	15	4	32	/	16,25	/	M4
20	160	37	23	38	18	12	65	68	20	6	40	23	16,25	40	M6
25	160	37	23	38	18	12	65	68	20	6	40	23	16,25	40	M6

Ø mm	P ₂	P ₃	P ₄	P ₅	P ₇	P ₈	P ₉	P ₁₃	P ₂	R	SP	SP ₁	SW ₁	SW ₂	SW ₃
12	8,5	M4	5,5	5,5	4,5	7	4,5	/	/	6,5	3	3	10	19	8
16	8,5	M4	5,5	5,5	4,5	7	4,5	/	/	6,5	3	3	10	19	8
20	10,5	M5	6,5	7	5,5	9	6	5	5	8,5	3	22	13	27	13
25	10,5	M5	6,5	7	5,5	9	6	5	5	8,5	3	22	17	27	13

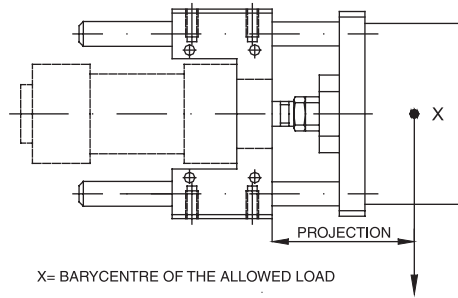

Graph of the maximum allowed load according to the projection (vertical loading plane)

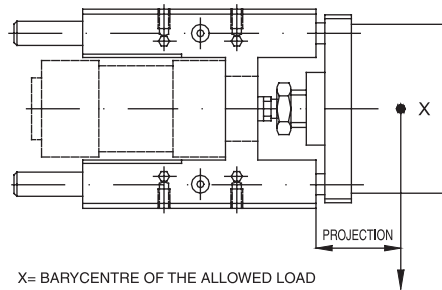
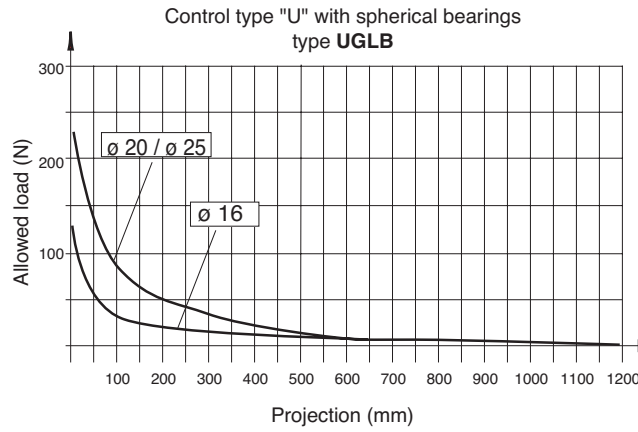

Graph of the maximum allowed load according to the projection (vertical loading plane)

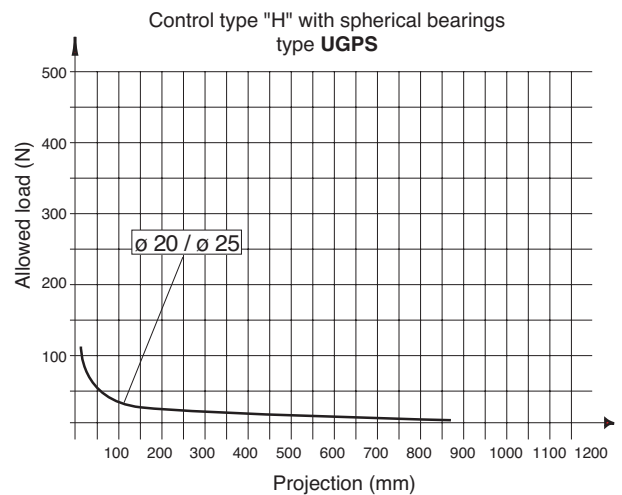
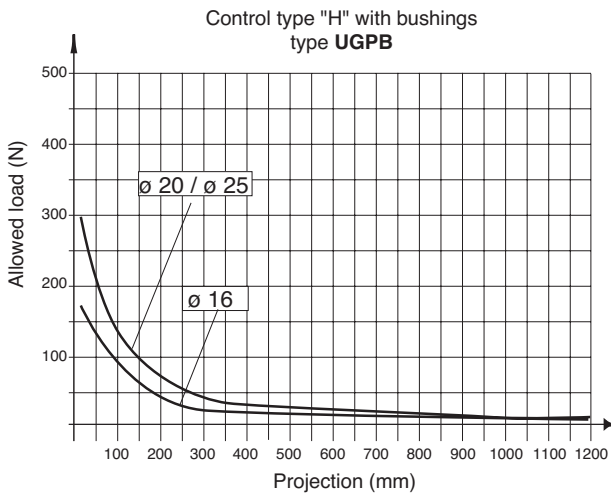

Slide Units for Cylinders DIN ISO 6431 and VDMA 24 562

Bores from 32 to 100 mm



Standard executions		
Version	Symbol	Type
U-shaped (light) with sintered bronze bushings		UGLB
H-shaped (heavy) with sintered bronze bushings		UGPB
H-shaped (heavy) with spherical bearings		UGPS

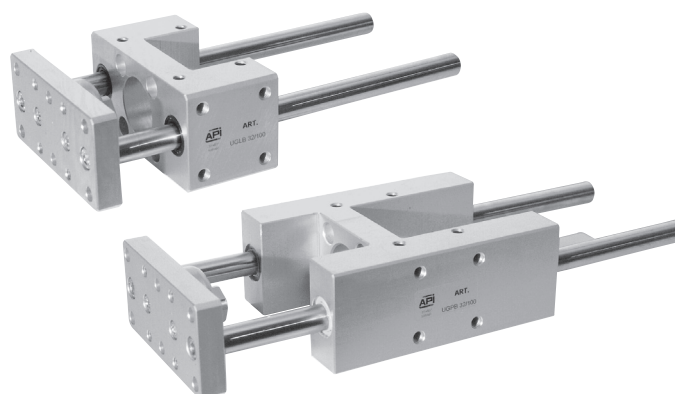

On request, they can be supplied according Directive 94/9/EC - **ATEX**
CE **II 2 G Dc T5**

Series of linear slide units for cylinders DIN ISO 6431 and VDMA 24 562 with 4 possible fixing surfaces. They must be used with heavy loads to guarantee a better linearity of movement and a higher precision. They can sometimes be used as anti-rotating devices too. The versions with spherical bearings slide better but can support lighter loads than the version with bronze bushings. The U-shaped versions, can support lighter loads than the H-shaped ones.

Options	Suffix
Rods in stainless steel AISI 316	K
Special versions on request	/ S

For loads see pages 1.70.25 - 1.70.30.
 For mounting accessories see from page 1.70.40.

The options can be combined (when this is possible)

How to order: UGPS40/200K

UGPS	40	/	200	K
Type	Cylinder bore	/	Cylinder stroke	Option

Technical data	
Temperature range	-20 °C ÷ + 70°C
Materials	Body: Anodised aluminium Plate: Anodised aluminium Seals: Polyurethane Bushings: UGLB-UGPB: Sintered bronze UGPS: Spherical bearings Rods: UGLB-UGPB: Chrome plated steel C45 UGPS: Hardened and chrome plated steel CF51

Cylinder bore (mm)	Standard strokes of cylinders D. A. (mm)	Maximum stroke of cylinders D. A. (mm)
32	25, 50, 80, 100, 125, 160, 200, 250, 300, 320, 400, 500	2500
40		
50		
63		
80		
100		

Seal kits not available.

Slide Units for Cylinders DIN ISO 6431 and VDMA 24 562

Bores from 32 to 100 mm



Type: UGLB

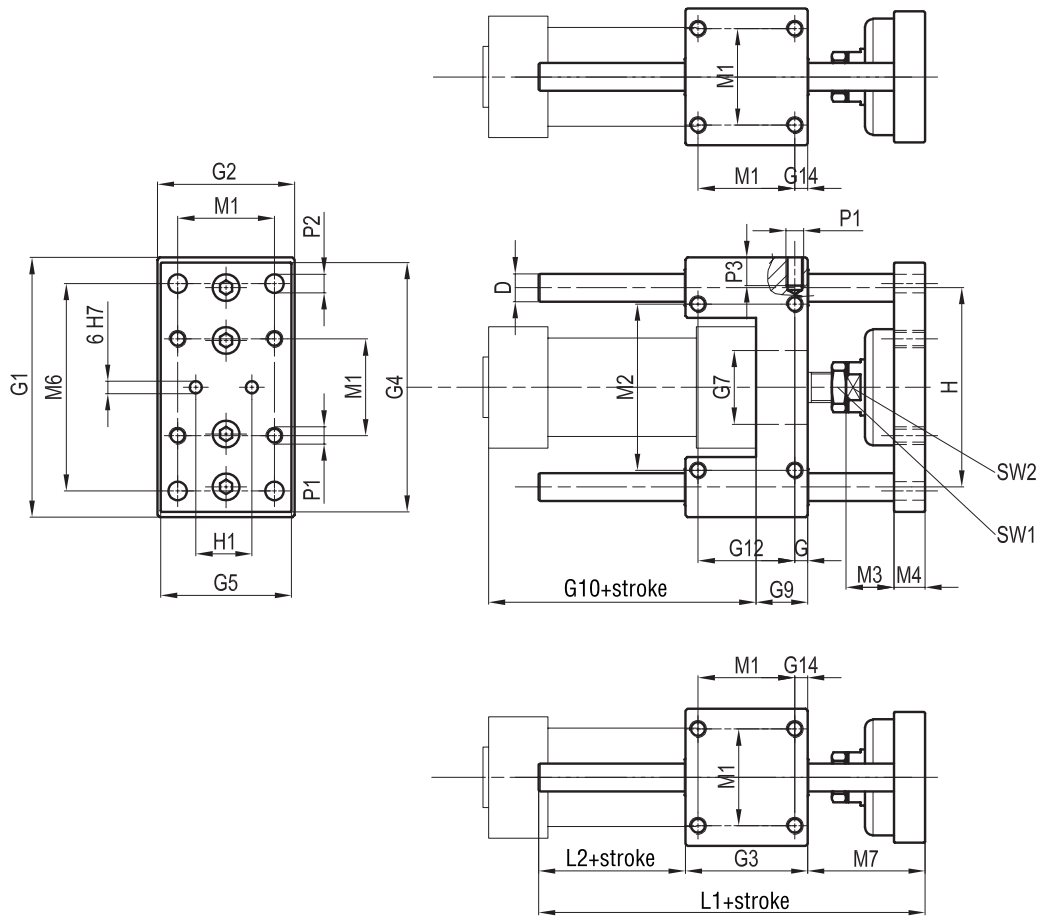

Ø mm	D	G	G ₁	G ₂	G ₃	G ₄	G ₅	Ø G ₇	G ₉	G ₁₀	G ₁₂	G ₁₄	H	H ₁
32	12	7,8	100	48	48	95	45	30	17	94	32,5	7,8	74	31
40	12	10	106	56	58	101	53	35	21	105	38	10	80	36
50	16	6,3	125	66	59	120	63	40	25	106	46,5	6,3	96	45
63	16	9,8	132	76	76	127	73	45	25	121	56,5	9,8	104	45
80	20	20	165	98	90	160	95	45	34	128	50	9	130	56
100	20	20	185	118	110	180	115	55	39	138	70	10,5	150	56

Ø mm	M ₁	M ₂	M ₃	M ₄	M ₆	M ₇	L ₁	L ₂	ø P ₁	P ₂	P ₃	SW ₁	SW ₂
32	32,5	58	23	11	78	46	108	14	M6	6,5	12	15	17
40	38	64	23	15	84	52	120	10	M6	6,5	12	15	17
50	46,5	80	24	15	100	65	130	6	M8	8,5	15	22	24
63	56,5	95	24	15	105	65	145	4	M8	8,5	15	22	24
80	72	130	30	16	130	71	170	9	M10	11	18	27	27
100	89	150	30	18	150	71	190	9	M10	11	18	27	27

Type: UGPB-UGPS

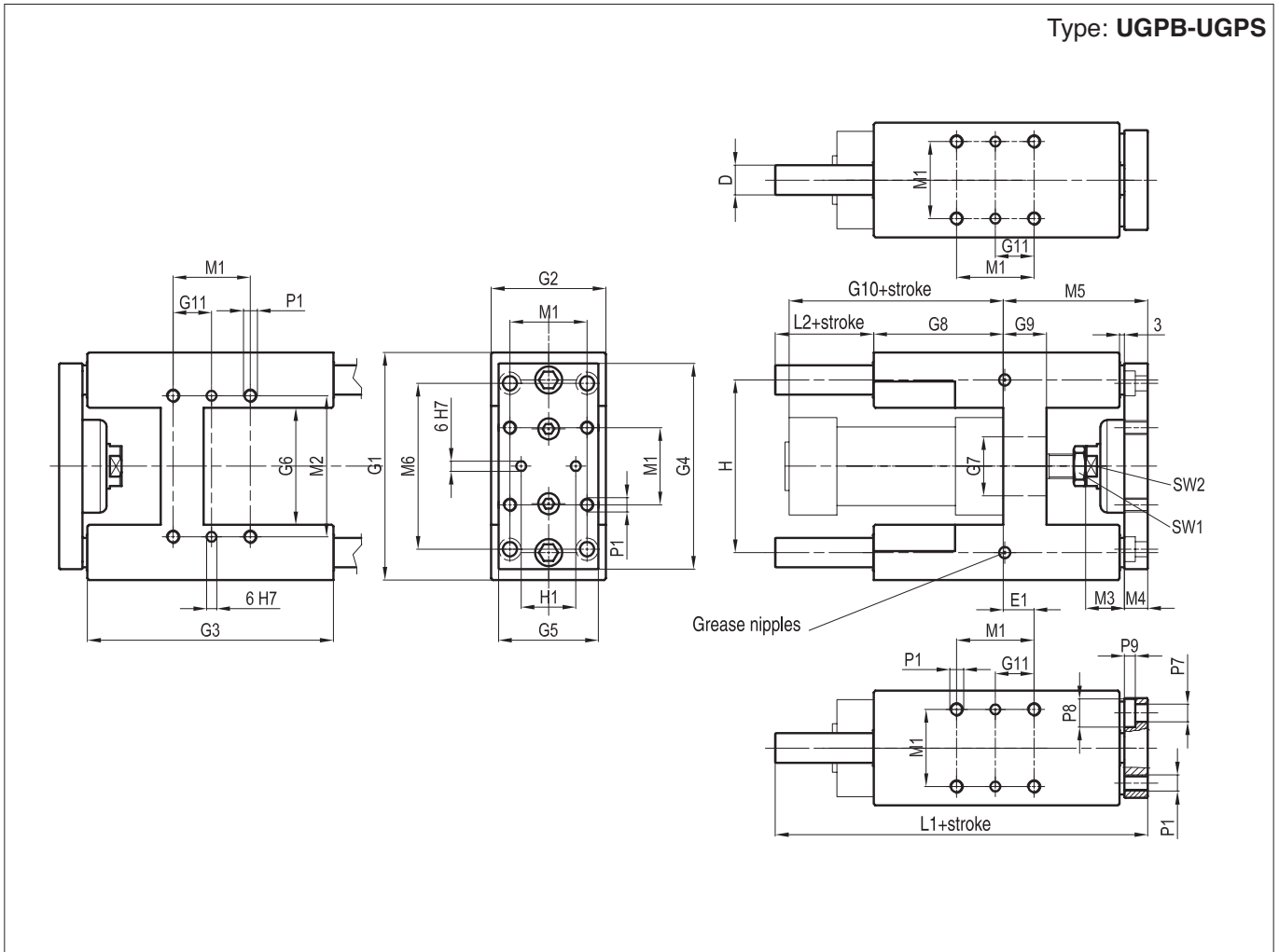

Ø mm	D	E ₁	G ₁	G ₂	G ₃	G ₄	G ₅	G ₆	Ø G ₇	G ₈	G ₉	G ₁₀	G ₁₁	H	H ₁
32	12	4,3	97	49	125	90	45	50,2	30	76	17	94	16,25	74	31
40	16	11	115	58	139	110	54	58,2	35	81	21	105	19	87	36
50	20	18,8	137	69	148	124	60	70,2	40	78	26	106	23,25	104	45
63	20	15,3	152	85	178	145	79	85,2	45	107	26	121	28,25	119	46
80	25	21	189	105	215	180	99	106	45	128	34	128	36	148	56
100	25	24,5	213	129	220	200	120	131	55	128	39	138	44,5	172	56

Ø mm	M ₁	M ₂	M ₃	M ₄	M ₅	M ₆	L ₁	L ₂	Ø P ₁	Ø P ₇	Ø P ₈	P ₉	SW ₁	SW ₂
32	32,5	61	23	11	63	78	177	38	M6	6,5	10,5	6,5	15	17
40	38	69	23	15	76	84	192	35	M6	6,5	10,5	6,5	15	17
50	46,5	85	24	15	88	100	205	39	M8	8,5	13,5	9	22	24
63	56,5	100	24	15	89	105	237	41	M8	8,5	13,5	9	22	24
80	72	130	30	20	110	130	280	42	M10	11	18	11	27	27
100	89	150	30	20	115	160	280	37	M10	11	18	11	27	27

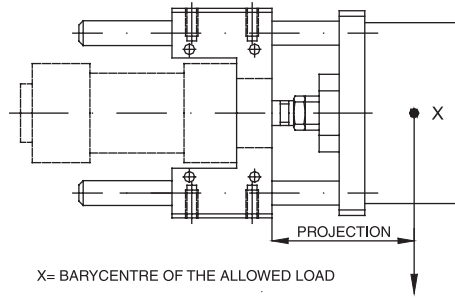

Graph of the maximum allowed load according to the projection (vertical loading plane)

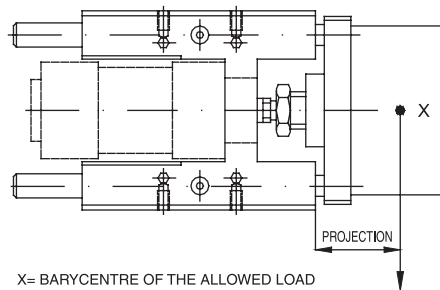
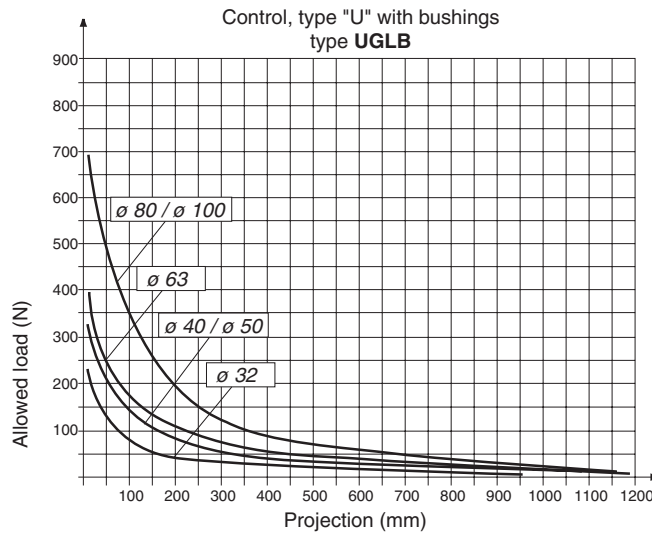

Graph of the maximum allowed load according to the projection (vertical loading plane)

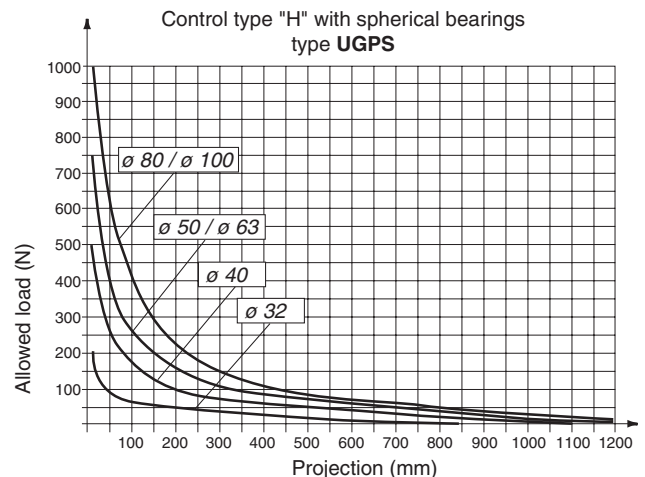
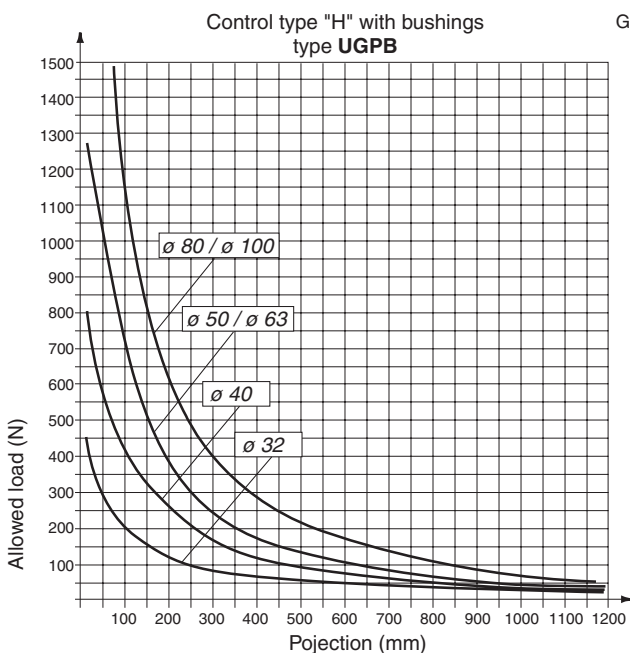

Connecting bracket for rods

Type: SCSG

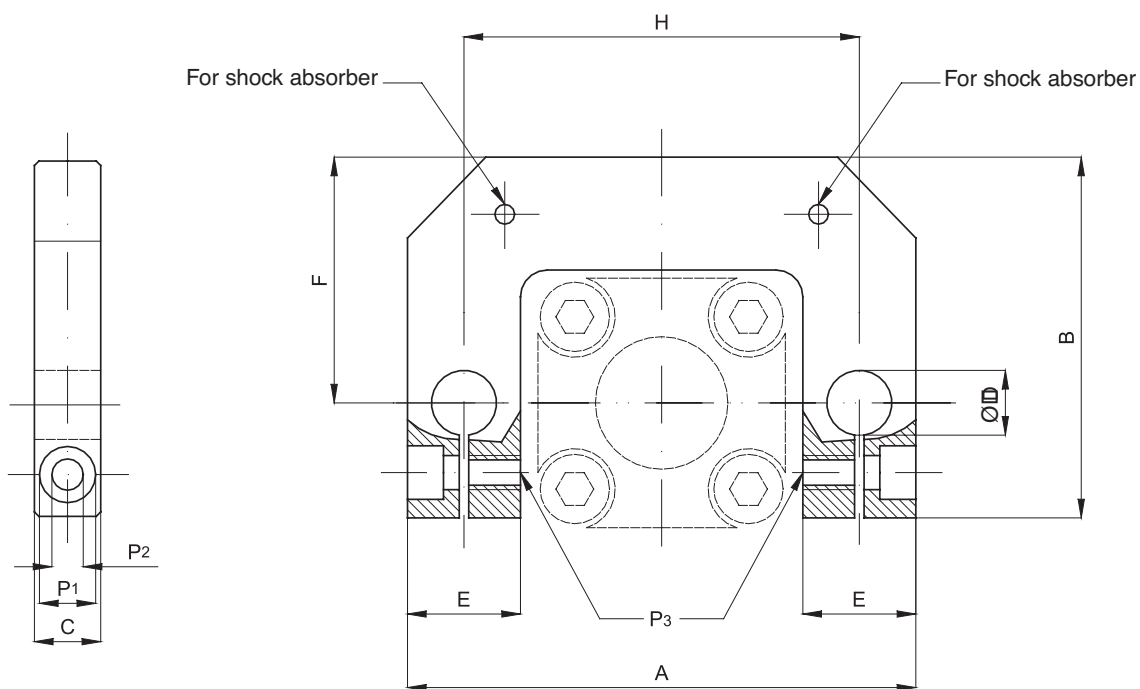

Code	Item	For cyl. ø mm	A	B	C	D ø	E	F	H	P ₁	P ₂	P ₃
077901	SCSG032	32	95	68	12	12	21	46	74	10,5	6,5	M6
077902	SCSG040	40	113	78	15	15	26	56	87	10,5	6,5	M6
077903	SCSG050	50	135	98	17	20	30	66	104	10,5	6,5	M6
077904	SCSG063	63	149	118	17	20	31	78	119	13,5	8,5	M8
077905	SCSG080	80	187	142	20	25	39	99	148	13,5	8,5	M8
077906	SCSG100	100	211	163	20	25	39	114	172	13,5	8,5	M8

For shock absorbers see page 1.105.1.