

# Compact Guided Cylinders

Bores from 10 to 63 mm

Double acting



Standard executions		
Version	Symbol	Type
With self-lubricating bushings		<b>GEDB</b>
With spherical bearings		<b>GEDS</b>



On request, they can be supplied according Directive 94/9/EC - **ATEX**  
**CE** **II 2 GDc T5**

Options	Suffix
Seals FKM max 150 °C	<b>V</b>
Special versions on request	<b>/ S</b>

The options can be combined (when this is possible).

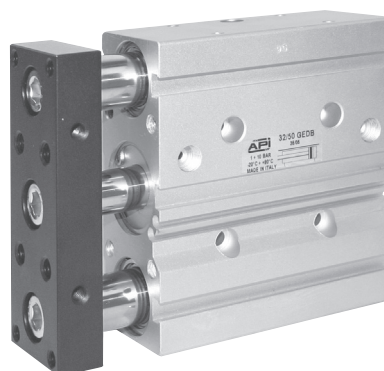

Series of compact guided cylinders magnetic as standard. A one piece body is provided with grooves allowing the mounting of the magnetic reed switch without further brackets; this makes the magnetic sensor not protrude outside the body itself. The bottom plates are provided with elastic cushionings.

For the magnetic reed switches type ASC see from page 1.110.1.

How to order: 32 / 50 GEDBV

32	/	50	GEDB	V
Bore	/	Stroke	Type	Option

Technical data	
Fluid	Compressed filtered air with or without lubrication
Pressure range	1,5 ÷ 9 bar
Temperature range	-10 °C ÷ + 70°C
Materials	Bottom plates: Anodised aluminium Body: Anodised aluminium Plate: Anodised aluminium Guiding rods: GEDB: Chrome-plated and ground steel GEDS: Chrome steel hardened and chrome-plated Piston rod: Chrome-plated steel C 45 Seals: Nitrile rubber (NBR) - Piston: Brass Guiding bushings : GEDB: Sintered bronze GEDS: Spherical bearings

Bore (mm)	Standard strokes (mm)	Max stroke (mm)
10	25, 50, 75, 100	100
16	25, 50, 75, 100, 125, 150, 175, 200	200
20		
25		
32	30, 50, 75, 100, 125, 150, 175, 200, 250	250
40		
50	30, 50, 75, 100, 125, 150	150
63		

See page 1.1.3 to calculate the cylinder force.

Should you require intermediate strokes, the overall dimensions of the cylinder body will be those of the cylinder with the following standard stroke (in fact the intermediate stroke is obtained applying a distancer).

#### Admissible transverse load

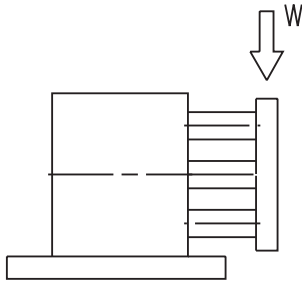

Bore mm	Type	Stroke mm						
		25	30	50	75	100	125	150
Ø 10	GEDB	8	6	4	8	6	4	3
	GEDS	1,5	1,2	1	4	3,5	3	2,5
Ø 16	GEDB	8	6	4	8	6	4	3
	GEDS	1,5	1,2	1	4	3,5	3	2,5
Ø 20	GEDB	14	12	10	12	10	8	5
	GEDS	2,5	2,1	2	8	6	4	3
Ø 25	GEDB	20	18	16	20	18	15	12
	GEDS	7	6	5	20	16	13	10
Ø 32	GEDB	27	24	22	24	22	20	18
	GEDS	9	8	7	25	22	27	18
Ø 40	GEDB	27	24	22	24	22	20	18
	GEDS	9	8	9	25	22	20	18
Ø 50	GEDB	45	42	40	45	40	35	30
	GEDS	12	11	9,5	40	32	28	25
Ø 63	GEDB	45	42	40	45	40	35	30
	GEDS	12	11	9,5	40	32	28	25

Note: Cylinders from 75 mm stroke are supplied with double guiding bushings.

#### Maximum admissible torque

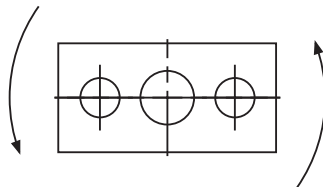

Bore mm	Type	Stroke mm						
		25	30	50	75	100	125	150
Ø 10	GEDB	25	20	15	25	20	15	10
	GEDS	3	2,5	2	4	3	2	1,5
Ø 16	GEDB	25	20	15	25	20	15	10
	GEDS	3	2,5	2	4	3	2	1,5
Ø 20	GEDB	40	35	30	40	35	30	25
	GEDS	4	3	2	15	12	10	8
Ø 25	GEDB	65	55	50	65	55	50	40
	GEDS	2	10	8	30	25	20	16
Ø 32	GEDB	90	80	70	90	75	60	45
	GEDS	18	16	14	50	45	40	35
Ø 40	GEDB	90	80	70	90	75	60	45
	GEDS	18	16	14	50	45	40	35
Ø 50	GEDB	150	130	110	150	120	100	80
	GEDS	35	30	25	100	85	70	55
Ø 63	GEDB	150	130	110	150	120	100	80
	GEDS	35	30	25	120	85	70	55

Note: Cylinders from 75 mm stroke are supplied with double guiding bushings.

#### Non-rotating accuracy

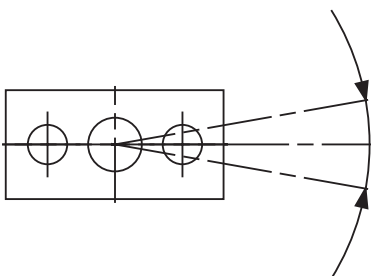

Bore mm	Non-rotating accuracy $\theta$
Ø 10 Ø 16	$\pm 0,18$
Ø 20 Ø 25	$\pm 0,17$
Ø 32 Ø 40	$\pm 0,16$
Ø 50 Ø 63	$\pm 0,15$

# Compact Guided Cylinders

Bores from 10 to 63 mm

Ø 10 - Ø 16



1

Ø 10

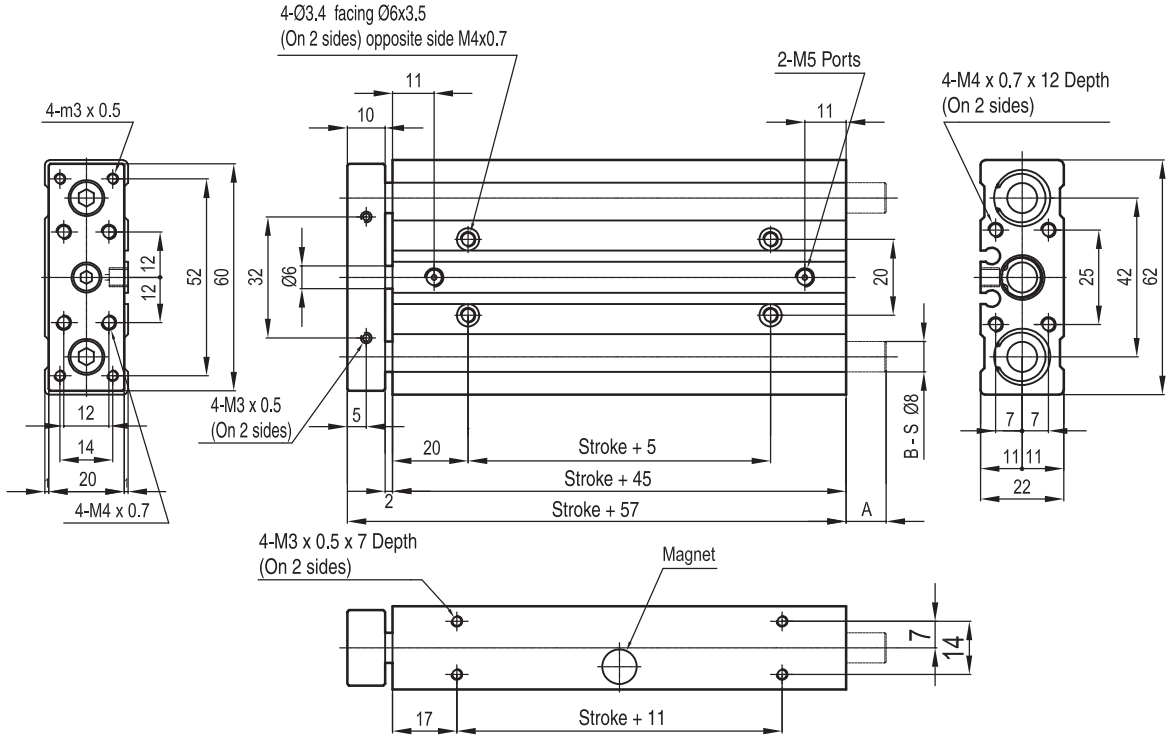

**COMPACT GUIDED CYLINDER**

Type: GEDB (S) 10 X 75 Stroke

Stroke mm.	25	50	75	100
Dimension A	0	0	10.5	10.5

Ø 16

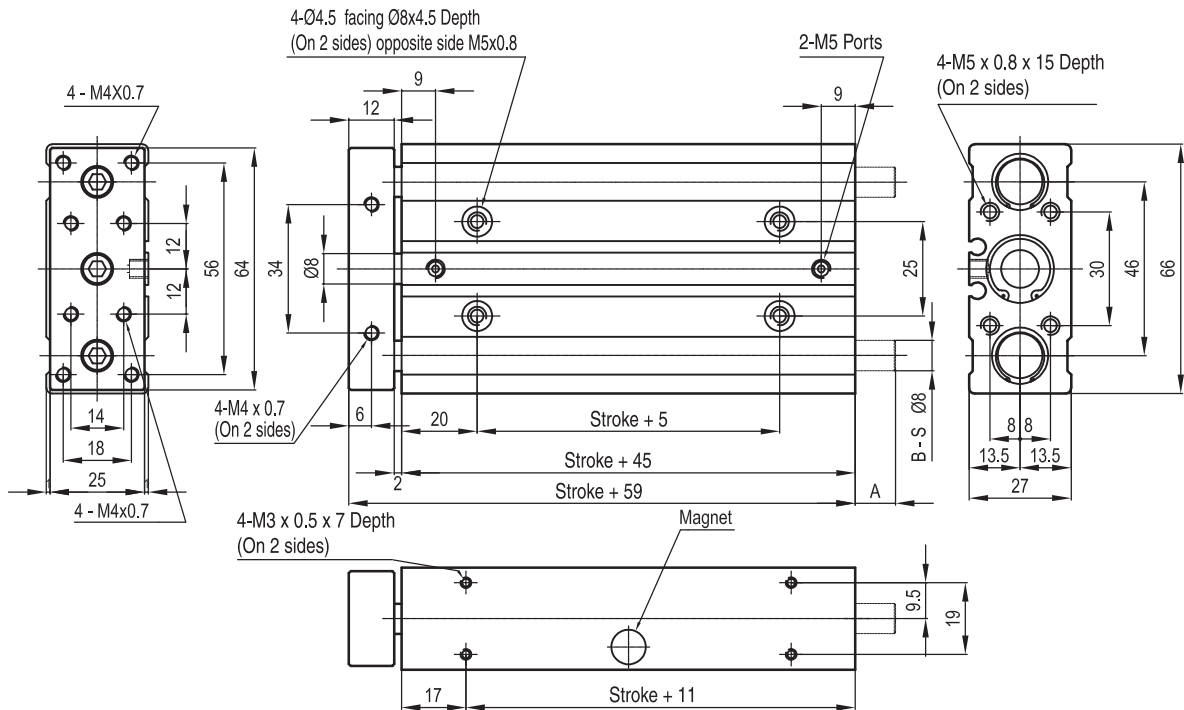

**COMPACT GUIDED CYLINDER**

Type: GEDB (S) 16 X 75 Stroke

Stroke mm.	25	50	75	100	125	150	175	200
Dimension A	0	0	12	12	12	12	12	12

# Compact Guided Cylinders

Bores from 10 to 63 mm

Ø 20 - Ø 25



Ø 20

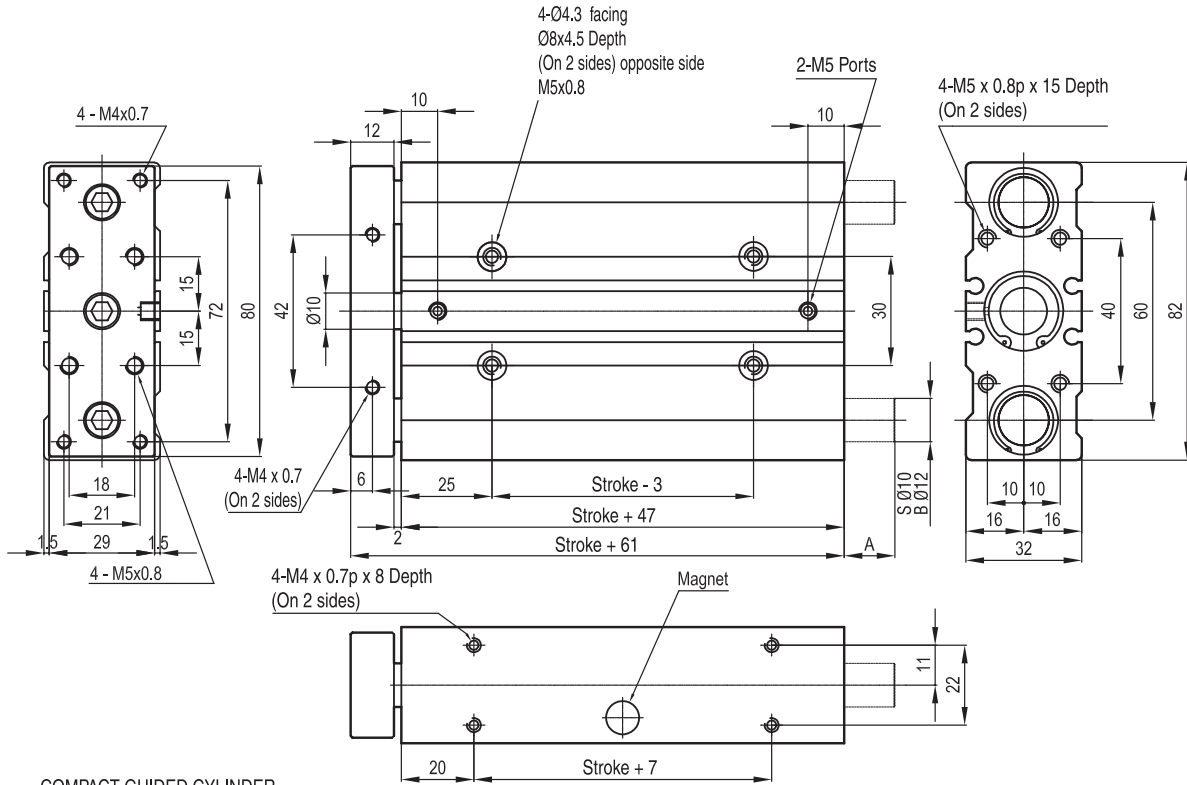

COMPACT GUIDED CYLINDER

Type: GEDB (S) 20 X 75 Stroke

Stroke mm.	25	50	75	100	125	150	175	200
Dimension								
A	0	0	14	14	14	14	14	14

Ø 25

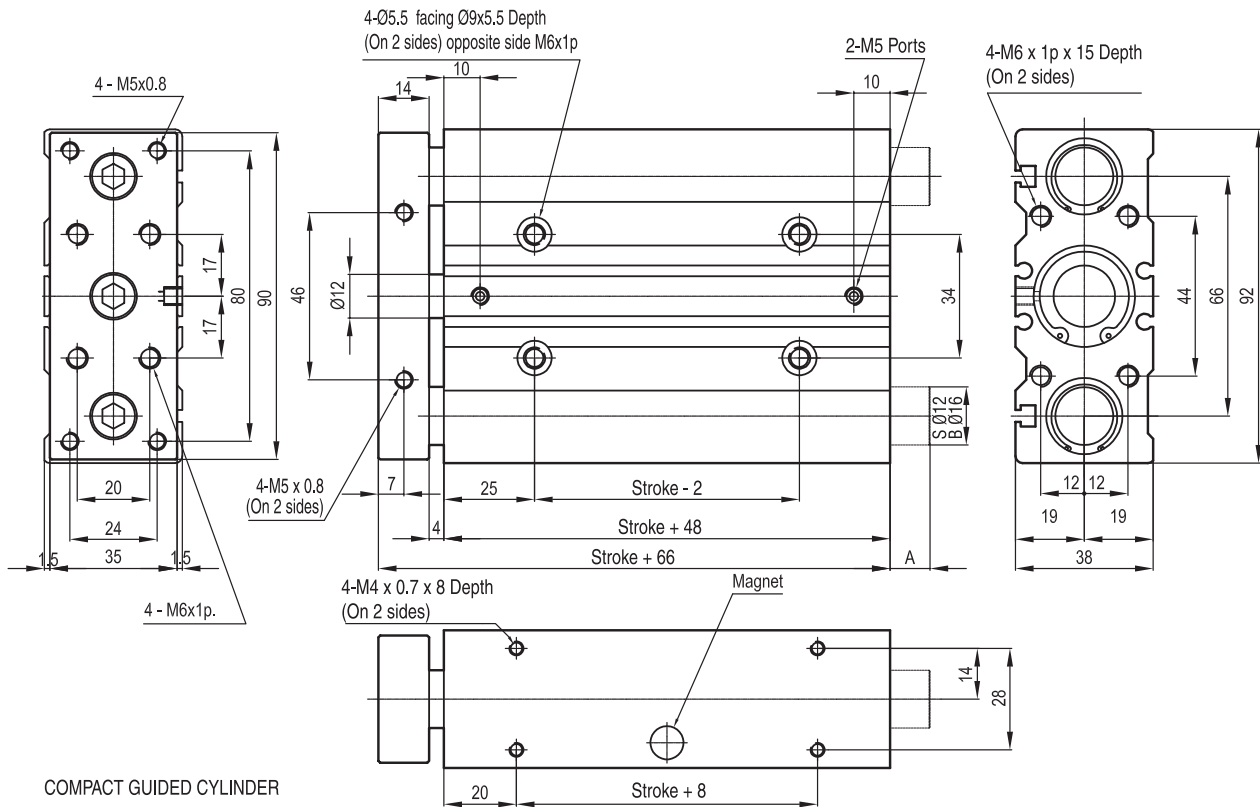

COMPACT GUIDED CYLINDER

Type: GEDB (S) 25 X 75 Stroke

Stroke mm.	25	50	75	100	125	150	175	200
Dimension								
A	0	0	11	11	11	11	11	11

# Compact Guided Cylinders

Bores from 10 to 63 mm

Ø 32 - Ø 40



1

Ø 32

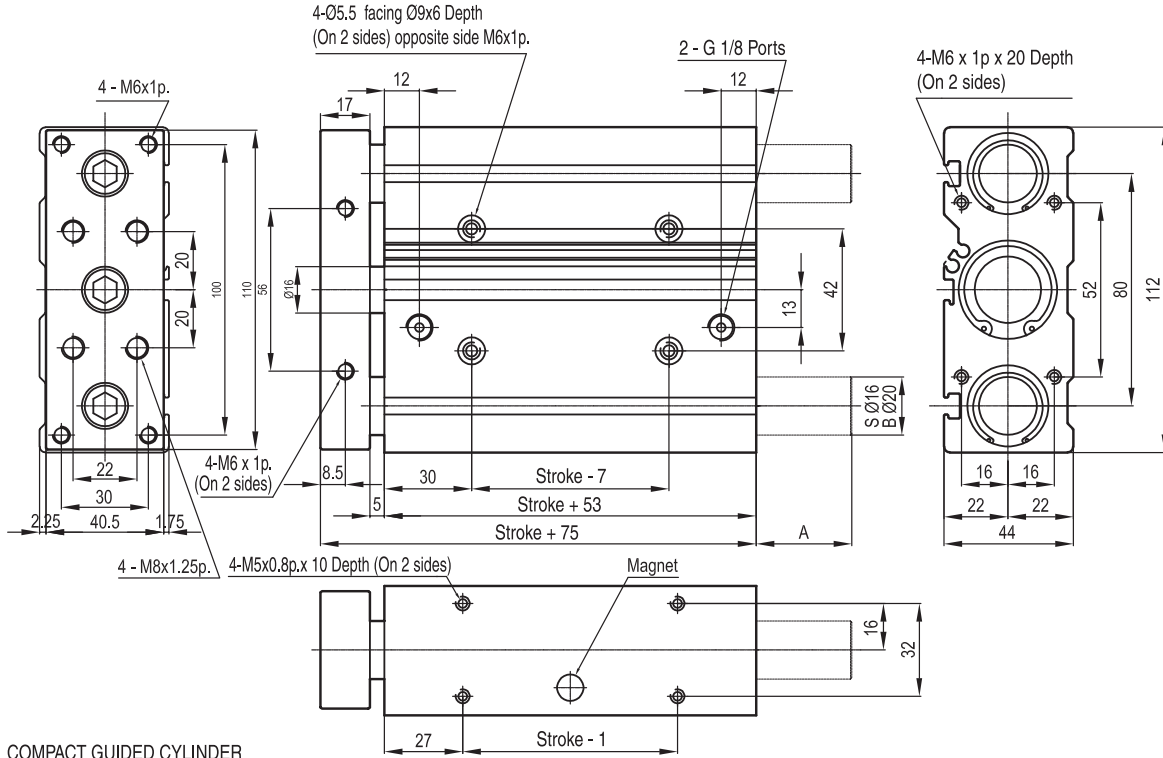

COMPACT GUIDED CYLINDER

Type: GEDB (S) 32 X 75 Stroke

Stroke mm.	30	50	75	100	125	150	175	200	250
Dimension A	0	0	33	33	33	33	33	33	33

Ø 40

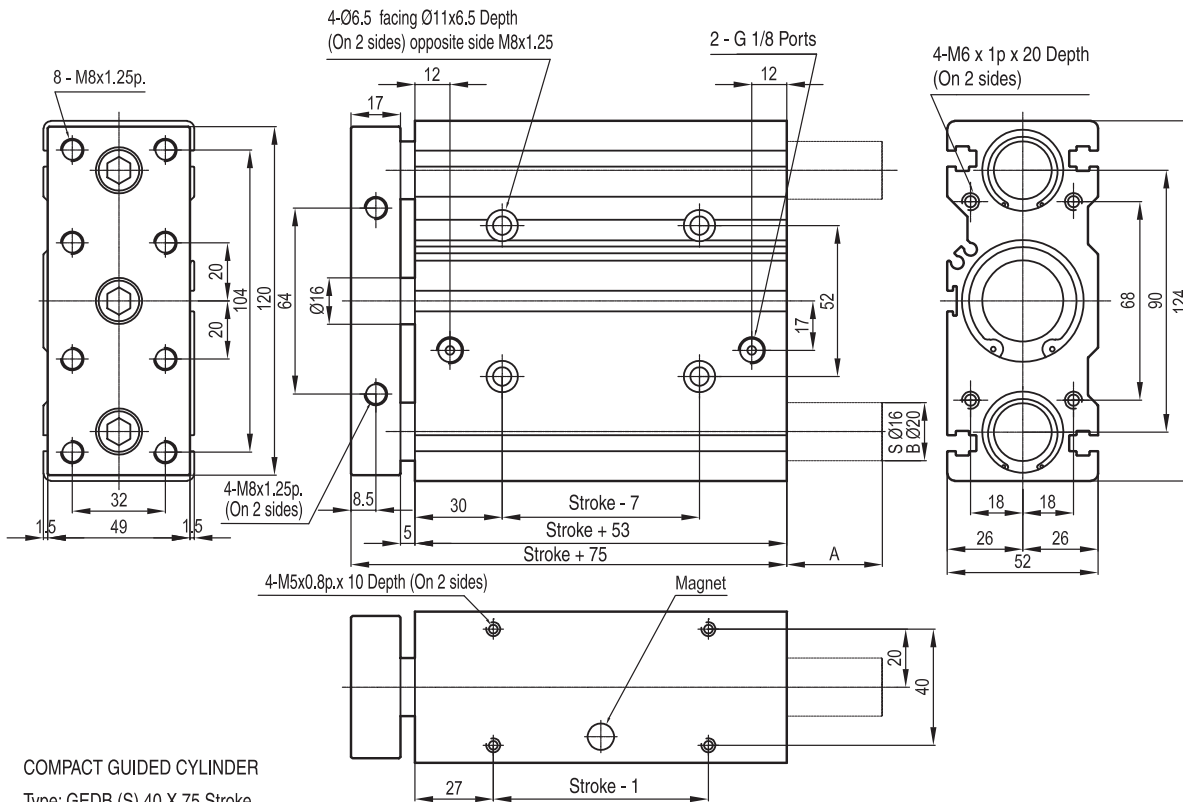

COMPACT GUIDED CYLINDER

Type: GEDB (S) 40 X 75 Stroke

Stroke mm.	30	50	75	100	125	150	135	200	250
Dimension A	0	0	33	33	33	33	33	33	33

# Compact Guided Cylinders

Bores from 10 to 63 mm

Ø 50 - Ø 63



Ø 50

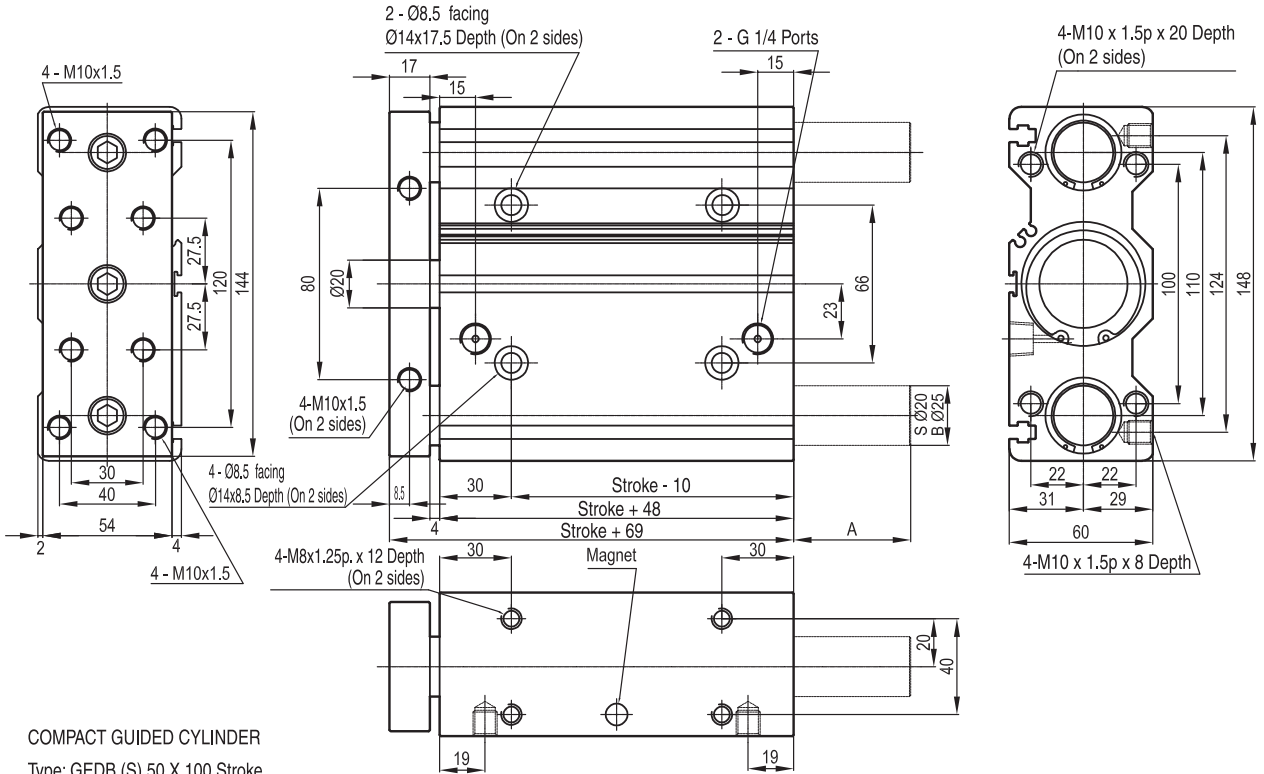

COMPACT GUIDED CYLINDER

Type: GEDB (S) 50 X 100 Stroke

Stroke mm.	30	50	75	100	125	150
Dimension						
A	0	0	0	49	49	49

Ø 63

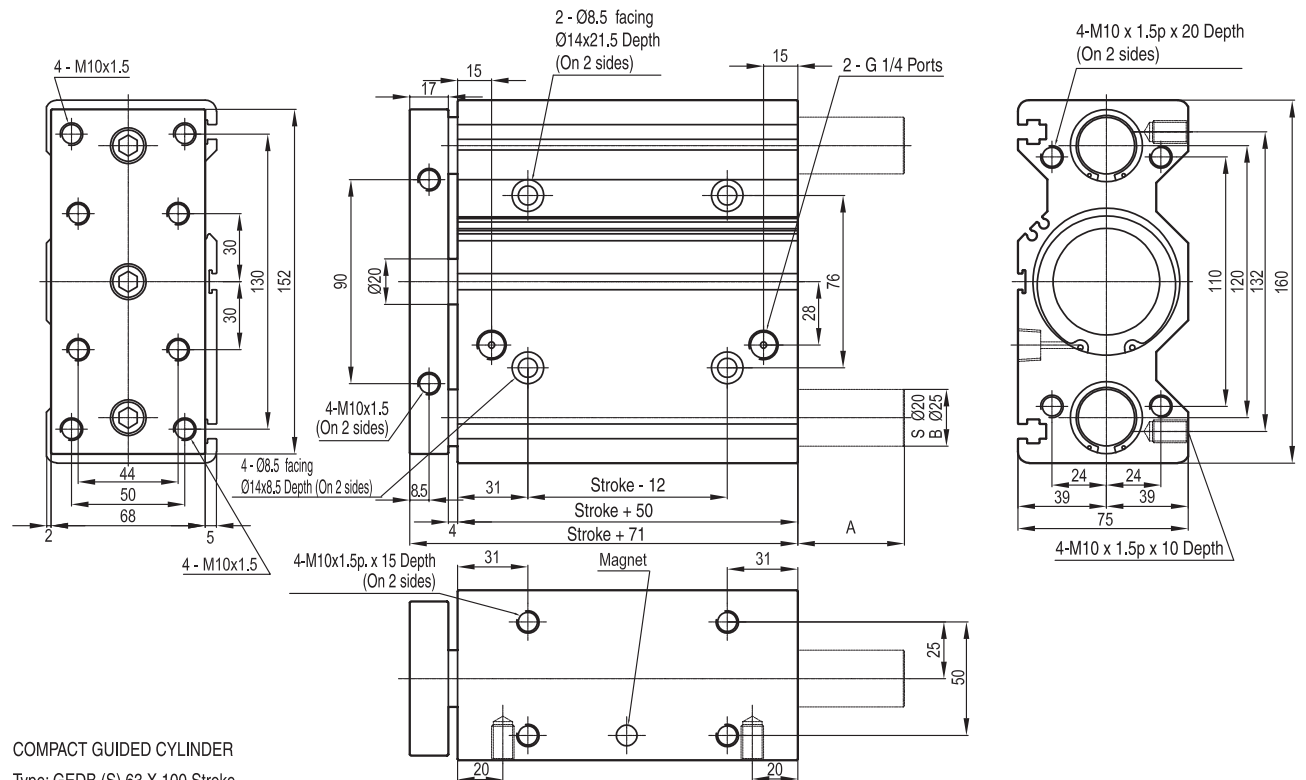

COMPACT GUIDED CYLINDER

Type: GEDB (S) 63 X 100 Stroke

Stroke mm.	30	50	75	100	125	150
Dimension						
A	0	0	0	47	47	47