

# Cylinders ISO 6432

Bores from 8 to 25 mm

Single acting



Standard executions		
Version	Symbol	Type
Non magnetic		MS
Magnetic		MSM



On request, they can be supplied according Directive 94/9/EC - **ATEX**  
**CE** **II 2 G Dc T5**

Options		Suffix
Through rod	from bore 16 to 25 mm.	<b>P</b>
Rear spring	from bore 16 to 25 mm.	<b>T</b>
Anti-rotating rod	from bore 16 to 25 mm.	<b>N</b>
Seals FKM	max 150 °C	<b>V</b>
Extended rod in hardened and chrome plated steel suitable for piston rod brake	from bore 12 to 25 mm.	<b>B</b>
Special versions on request		<b>/ S</b>

The options can be combined one another (when this is possible)



Series of cylinders conforming to ISO 6432 standards  
 The heads are connected with the body through rolling; this guarantees perfect fit.  
 The cushionings are in nitrile rubber to cushion the impact of the piston.  
 The standard cylinders are provided with head and rod nut.  
 One or more magnetic reed switches can be applied to the magnetic type.

For the magnetic reed switches type ASV see from page 1.110.1.

For mounting accessories see from page 1.95.1.

For rod accessories see from page 1.85.1.

For dimensions of the cylinder with the piston rod brake see page 1.75.5.

Seal kits not available for these cylinders.

How to order: 25 / 50 MSP

25	/	50	MS	P
Bore	/	Stroke	Type	Option

Technical data	
Fluid	Compressed filtered air with or without lubrication
Pressure	max 10 bar
Temperature range	-30 °C ÷ + 80°C
Materials	Heads: Anodised aluminium Tube: Stainless steel AISI 304 Rod: Stainless steel AISI 303 Seals: Polyurethane - Brass piston

Bore (mm)	Standard strokes (mm)	Max stroke (mm)	Thrust force at 6 bar (N)	Traction force of the spring (N)					
				Stroke 10		Stroke 25		Stroke 50	
				min.	max	min.	max	min.	max
8	10, 25, 50	50	20	4,8	5,3	4	5,3	3,2	5,3
10			35	4,8	5,3	4	5,3	3,2	5,3
12			50	6,3	6,9	5,4	6,9	3,9	6,9
16			90	13,1	14	11,8	14	9,7	14
20			148	18,1	19,4	16,4	19,4	13,4	19,4
25			250	22,9	23,9	21,1	23,9	17,7	23,9



Type: MS-MSM

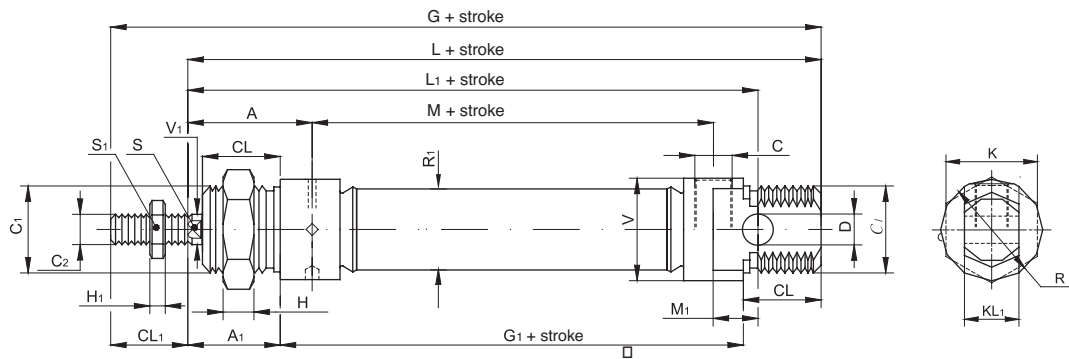

ø mm	C <sub>2</sub>	V <sub>1</sub>	C <sub>1</sub>	R	KL <sub>1</sub>	R <sub>1</sub>	V	D	CL <sub>1</sub>	L <sub>1</sub>	L	M	G <sub>1</sub>	A <sub>1</sub>	CL	A	M <sub>1</sub>	S	C	G	K	H	H <sub>1</sub>	S <sub>1</sub>
8	M4	4	M12x1,25	16	8	9,27	15	4	12	64	74	12	46	16	12	21	6	/	M5	86	19	6	2	7
10	M4	4	M12x1,25	16	8	11,27	15	4	12	64	74	12	46	16	12	21	6	/	M5	86	19	6	2	7
12	M6	6	M16x1,5	19	12	13,27	18	6	16	75	88	18	48	22	18	27	9	5	M5	104	22	5	3	10
16	M6	6	M16x1,5	21	12	17,27	19	6	16	82	96	16	58	22	16	27	2	5	M5	112	19	5	3	12
20	M8	8	M22x1,5	30	16	21,27	28,5	8	20	95	105	22	59	24	18	31,5	12	7	1/8"	125	27	8	4	14
25	M10x1,25	10	M22x1,5	30	16	26,5	28,5	8	22	104	114	22	64	28	20	36	12	9	1/8"	136	27	8	6	17

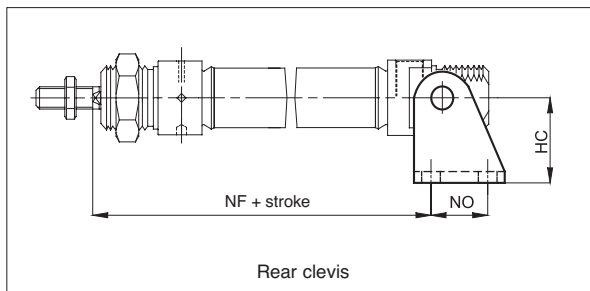
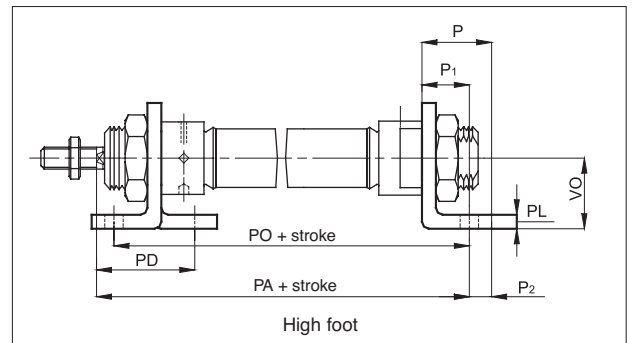
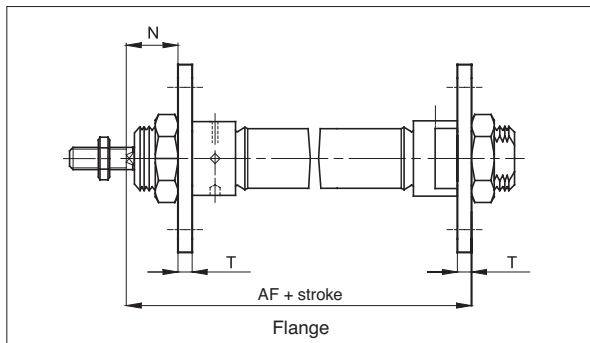

ø mm	AF	HC	P	P <sub>1</sub>	P <sub>2</sub>	PA	PD	PL	PO	T	VO	N	NF	NO
8	65	24	16	11	5	73	24	3	68	3	16	13	62,5	12,5
10	65	24	16	11	5	73	24	3	68	3	16	13	62,5	12,5
12	76	27	20	14	6	86	32	4	78	4	20	18	73	15
16	84	27	20	14	6	94	32	4	86	4	20	18	80	15
20	88	30	25	17	8	100	36	5	93	5	25	19	91	20
25	97	30	25	17	8	109	40	5	98	5	25	23	100	20

For dimensions and codes of the accessories see page 1.95.1.